

**ICC Evaluation Service, Inc.**  
[www.icc-es.org](http://www.icc-es.org)

**Business/Regional Office** ■ 5360 Workman Mill Road, Whittier, California 90601 ■ (562) 699-0543  
**Regional Office** ■ 900 Montclair Road, Suite A, Birmingham, Alabama 35213 ■ (205) 599-9800  
**Regional Office** ■ 4051 West Flossmoor Road, Country Club Hills, Illinois 60478 ■ (708) 799-2305

**DIVISION: 06—WOOD AND PLASTICS**  
**Section: 06120—Structural Panels**

**REPORT HOLDER:**

**INSULFOAM, LLC**  
**d/b/a PREMIER BUILDING SYSTEMS**  
**1019 PACIFIC AVENUE, SUITE 1501**  
**TACOMA, WASHINGTON 98402**  
**(952) 447-5213**  
[www.pbssips.com](http://www.pbssips.com)  
[tsavoy@insulfoam.com](mailto:tsavoy@insulfoam.com)

**EVALUATION SUBJECT:**

**PREMIER STRUCTURAL SANDWICH PANELS: TYPE S,  
TYPE I and TYPE L**

**1.0 EVALUATION SCOPE**

**Compliance with the following codes:**

- 2006 *International Building Code*® (IBC)
- 2006 *International Residential Code*® (IRC)
- BOCA® *National Building Code/1999* (BNBC)
- 1999 *Standard Building Code*® (SBC)
- 1997 *Uniform Building Code*™ (UBC)

**Properties evaluated:**

- Structural
- Fire-resistance

**2.0 USES**

Premier Structural Sandwich Panels are used as roof and floor and load-bearing and nonload-bearing wall panels of Type V construction. When installed in accordance with Section 4.2.5, 4.2.6 or 4.2.7, the panels may be used as components of one-hour fire-resistance rated assemblies.

When panels are installed under the IRC, an engineered design is required in accordance with IRC Section R301.1.3.

**3.0 DESCRIPTION**

**3.1 General:**

Premier Structural Sandwich Panels are factory-assembled, laminated, sandwich panels produced at locations listed in Table 1 of this report. The panels consist of expanded polystyrene (EPS) cores with wood-based structural-use sheathing facings. The panels are manufactured in Type S, Type I and Type L panel configurations as shown in Figures 1, 2, and 3, respectively. Type S panels are produced in widths ranging from 4 feet (1219 mm) to 8 feet (2438 mm) and lengths ranging from 8 feet (2438 mm) to 24 feet (7315 mm).

Type I and Type L panels are produced in maximum 4 foot (1219 mm) widths and lengths up to 24 feet (7315 mm).

**3.1.1 Type S Panel:** The core for the Type S panel is recessed along the panel sides to receive nominal 3-inch-wide (76 mm) OSB splines and recessed on the ends to receive solid sawn dimensional lumber sized to match the core thickness. See Figure 1 and Tables 2, 5 and 7.

**3.1.2 Type I Panel:** The Type I panel is recessed along the panel's sides to receive I-joist splines and recessed on the ends to receive nominal 2-by solid sawn lumber sized to match the core thickness. See Figure 2 and Table 3.

**3.1.3 Type L Panel:** The Type L panel is recessed along the panel sides and ends to receive nominal 2-by solid sawn dimensional lumber sized to match the core thickness. See Figure 3 and Tables 4, 6 and 7.

**3.2 Materials:**

**3.2.1 Core:** The core material is Insulfoam Type I expanded polystyrene (EPS) foam plastic ([ESR-1788](#)) with a nominal thickness ranging from 3<sup>1</sup>/<sub>2</sub> inches (89 mm) to 11<sup>1</sup>/<sub>4</sub> inches (285 mm). The EPS is a Type I expanded polystyrene with a nominal density of 1 pcf (16 kg/m<sup>3</sup>) complying with ASTM C 578. The EPS has a flame spread index of not more than 75 and a smoked developed index of not more than 450 when tested in accordance with ASTM E 84.

**3.2.2 Facing:** Panel facing material is 7/16, 1/2, 5/8 or 3/4-inch (11.1, 12.7, 15.9 or 19.1 mm) thick Exposure 1, oriented strand board (OSB) with span ratings of 24/16, 32/16, 40/20, and 48/24, respectively, and complying with the performance-rated panel requirements specified in United States Voluntary Product Standard PS-2 (UBC Standard 23-3). The OSB is supplied by manufacturers listed in the approved quality control documentation.

**3.2.3 Adhesive:** The adhesive is a Type II, Class 2 laminating adhesive as specified in the approved quality control documentation, complying with the ICC-ES Acceptance Criteria for Sandwich Panel Adhesives (AC05).

**3.2.4 Splines:** The splines for the Type S panels are nominal 3-inch-wide-by-7/16-inch-thick (76 by 11 mm) OSB as described in Section 3.2.2.

Splines for Type I panels must be Superior Wood Systems I-joists with 3-inch-wide (76 mm) by 1<sup>1</sup>/<sub>2</sub>-inch thick (38 mm) 2100f-1.8E MSR wood flanges and 7/16-inch-thick (11.1 mm) OSB webs, sized in depth to match the core thickness.

The splines for Type L panels must be nominal 2-by dimensional lumber sized in depth to match the core thickness. Splines must be a minimum of No. 2 hem-fir with a specific gravity of 0.43. See Figures 1, 2 and 3.

**3.2.5 Horizontal Diaphragm Fasteners:** When the panels are used in horizontal diaphragms, the fasteners used to attach the panels to underlying supports, must be Premier

Building Systems (PBS) proprietary screws. The screws are steel screws with a 0.635-inch (16.13 mm) head diameter, 0.19-inch (4.83 mm) nominal shank diameter, 0.245-inch (6.22 mm) minimum thread diameter and various lengths.

## 4.0 DESIGN AND INSTALLATION

### 4.1 Design:

The allowable transverse, uniform axial, axial point, header, shearwall and diaphragm loads are as shown in Tables 2 through 11. Unless noted otherwise, the allowable transverse loads are uniform loads for panels installed under simply supported single span conditions. Where loading conditions result in the panels resisting combined stresses, the sum of the ratios of actual loads over allowable loads must be less than 1.0

### 4.2 Installation:

**4.2.1 General:** The panels must be installed in accordance with the manufacturer's published installation instructions and this report. A copy of the installation instructions must be available at all times on the jobsite during installation.

The panels must be connected to each other along their edges with field-installed OSB splines, I-joist splines or dimensional lumber splines. Unless noted otherwise in this report, OSB facings must be attached to the splines with 8d box nails, or equivalent, spaced at 6 inches (152 mm) on center.

Top and bottom plates installed into the recessed core of the wall panels are dimensional lumber, sized to match the core thickness, and fastened to both panel facings with 8d box nails, or equivalent, spaced at 6 inches (152 mm) on center. Unless noted otherwise in this report, an EPS-compatible sealant is applied along butting EPS core surfaces and any dimensional lumber surfaces, and along the bottom of the panel base plate before panel placement. Typical installation details are in Figures 4 through 14. Structural calculations must be prepared to substantiate the details for the specific installation and loading conditions.

The wall panels used as bearing walls must be installed in a manner such that both panel facings of the wall panels are in contact, and sufficiently supported by the underlying structure; and the axial loads are uniformly and concentrically applied to the full thickness of the panels, including panel facings.

Sill plates must be preservative-treated for decay resistance where required by IBC Section 2304.11.2.3, IRC Section R319, BNBC Section 2311.4.3, SBC Section 2304.4.1 and UBC Section 2306.4, as applicable.

**4.2.2 Wall Openings:** The allowable gravity loads for the sandwich panels used as headers over wall openings are noted in Tables 8 and 9 of this report. Headers must have minimum  $7/16$ -inch-thick (11.1 mm) facings and  $3\frac{1}{2}$ -inch-thick (89 mm) cores. Joints are permitted, provided the 2-by dimensional lumber top and bottom plates are continuous and connected to the facings with 8d common or box nails spaced 6 inches (152 mm) on center, or equivalent. Minimum bearing at supports is  $1\frac{1}{2}$  inches (38 mm), and both OSB facings must be supported. The minimum width of the panel between openings is 12 inches (305 mm). For other conditions, conventional framing techniques with headers must be designed and installed to the satisfaction of the code official.

**4.2.3 Horizontal Diaphragm:** See Table 11 and Figure 15 for the installation of Premier sandwich panels combined with wood-framing to form a horizontal diaphragm. Table 11 and Figure 15 also include types of fasteners and fastener spacing.

### 4.2.4 Thermal Barrier:

**4.2.4.1 Wall, Roof and Floor:** One-half-inch-thick (12.7 mm), regular gypsum wallboard complying with ASTM C36 or C1396 must be installed on the interior surface of wall and roof panels and the bottom side of floor panels having occupied space below the floor panel. The wallboard must be fastened to the face of the panels with 5d wallboard nails, or minimum  $1\frac{1}{4}$ -inch-long (31.7 mm), No. 6 Type S or Type W drywall screws spaced in accordance with ASTM C 840 for use under the IBC, Table R702.3.5 of the IRC, or Table 25-G of the UBC using 16-inch-on-center (406.4 mm) framing spacing guidelines.

**4.2.4.2 Floor Panels:** An approved thermal barrier is required on the top surface of floor panels. See the footnotes in Tables 2, 3 and 4.

### 4.2.5 Panel Cladding:

**4.2.5.1 Roof Covering:** The roof covering must comply with Chapter 15 of the IBC, BNBC, SBC or UBC, or IRC Section R901, as applicable. Roofs with hot-asphalt or hot-coal tar pitch are prohibited. Underlayment and flashing must be installed in accordance with the applicable code.

**4.2.5.2 Exterior Wall Covering:** The exterior face of wall panels are required to be covered with a wall covering, complying with the applicable code or recognized in a current ICC-ES evaluation report. A water-resistive barrier must be installed over the panels in accordance with IBC Section 1404.2, IRC Section R703.2, BNBC Section 1406.3.6, and UBC Section 1402, as applicable, prior to application of the wall covering. Where portland cement plaster is used, compliance with IBC Sections 2510 and 2512, IRC Section R703.6.3 or UBC Section 2506.4, as applicable, is necessary. All exterior panel joints must be sealed with a compatible acrylic latex caulk.

### 4.2.6 One Hour Fire-resistance-rated Limited Loadbearing Wall:

**4.2.6.1 General:** Walls constructed with the Premier Building System Type S panels, with minimum  $7/16$ -inch-thick (11 mm) OSB facings and a  $3\frac{1}{2}$ -inch-thick (92 mm) polystyrene foam plastic core, covered with two layers of  $5/8$ -inch-thick (15.9 mm) gypsum wallboard on both faces, are one hour fire-resistance-rated limited loadbearing walls when installed in accordance with this section of this report. The maximum allowable axial load is 61 percent of the allowable axial load noted in Table 5 for Type S panels with a  $3\frac{5}{8}$ -inch thick (92 mm) core, but not to exceed 1,833 pounds/foot (26.7 kN/m).

**4.2.6.2 Splines:** Nominal 4-inch-wide (102 mm) by  $7/16$ -inch-thick (11 mm) OSB splines must be installed between vertical joints, in precut channels in the core of the panels, beneath both panel facings. The splines must be secured to the OSB facings of the panels with an adhesive (APA AFG-01) and  $1\frac{5}{8}$ -inch-long (41 mm) Type S steel screws spaced 6 inches (152 mm) on center along the edges of each adjoining panel face.

**4.2.6.3 End Plates:** Nominal 2-by No. 2 Douglas fir-larch lumber with a depth to match the panels' core thickness must be installed at the top and bottom of panels in precut channels. The end plates must be secured to the OSB facer of the panels, with caulk complying with ASTM C 834 on the face in contact with the polystyrene core, and 8d box nails spaced 8 inches (203 mm) on center along the edge of both faces of the panels.

**4.2.6.4 Gypsum Board:** National Gypsum Co. Type FSW gypsum wallboard,  $5/8$ -inch thick (16 mm) by 4-foot-wide (1219 mm), must be applied vertically in two layers to both sides of the wall panels. The first layer must be installed with  $1\frac{5}{8}$ -inch-

long (41 mm) No. 6 Type S steel screws spaced 24 inches (610 mm) on center vertically and 16 inches (406 mm) on center horizontally. The vertical joints of the first gypsum board layer must be offset a minimum of 16 inches (406 mm) from the vertical spline joints of the sandwich panels. The second layer must be installed with 2-inch-long (51 mm) No. 6 Type S screws spaced 12 inches (305 mm) on center vertically and offset 12 inches (305 mm) from the first layer screws, and 16 inches (406 mm) on center horizontally, offset 8 inches (203 mm) from first layer screws. The second layer joints must be offset a minimum of 16 inches (406 mm) from the first layer joints. The joints of the second layer of wallboard must be covered with joint tape and joint compound in accordance with ASTM C 840 or GA-216. Screw heads on the second layer of wallboard must be covered with joint compound in accordance with ASTM C 840 or GA-216. Where the panels are used as exterior walls, the gypsum board must be gypsum sheathing.

**4.2.7 One-Hour-Fire-resistance-rated Limited Loadbearing Wall:** Walls constructed with the Type L panels with a 5 $\frac{1}{2}$ -inch-thick (140 mm) EPS core laminated between two sheets of  $\frac{7}{16}$  inch (11 mm) OSB covered with one layer of gypsum wallboard on both panel faces are one-hour fire-resistance-rated, limited loadbearing walls when installed in accordance with this section of this report. The maximum allowable axial load is 37 percent of the allowable axial load noted in Table 6 for Type L panels with a 5 $\frac{1}{2}$ -inch-thick (140 mm) core, or 2,200 plf (32 kN/m), whichever is less.

The EPS core must be recessed 1 $\frac{1}{2}$  inches (38 mm) in from the edges of the OSB facers on the bottom and along both sides, and 3 inches along the top, to allow for the installation of nominal 2-by-6 wood splines (No. 2 Hem-Fir minimum), bottom plate and double top plate.

Double 2-by-6 nominal wood splines must be installed into the recesses in the vertical edges of the panels. The double splines must be assembled using two nominal 2-by-6 wood splines nailed together with 16d coated sinker nails spaced at 24 inches (610 mm) on center, staggered along the stud length. The double splines must be installed in the recesses between the adjoining panels and secured to the OSB with 6d common nails spaced at 6 inches (152 mm) on center, after caulking the surfaces to be in contact with the EPS core with mastic. The single-bottom plate must be installed into the recess along the bottom edge of the wall assembly and secured to the OSB with 6d common nails spaced at 6 inches (152 mm) on center and to each wood spline with two 16d coated sinker nails, after caulking the surfaces to be in contact with the EPS core with mastic. The first top plate must be installed into the recess along the top of the wall assembly and secured to each wood spline with two 16d coated sinker nails, after caulking the surfaces to be in contact with the EPS core with mastic. The second top plate must be installed over the first and secured to the OSB with 6d common nails spaced at 6 inches (152 mm) on center and to the first top plate with 16d coated sinker nails spaced at 16 inches (406 mm) on center staggered along the top plate length.

A single layer of Temple Inland's Type TG-C,  $\frac{5}{8}$  inch (16 mm) thick, gypsum wallboard must be installed onto both faces of the wall. The wallboard must be secured to the OSB panel facers with 6d phosphate coated, cupped-head-drywall nails, 1 $\frac{5}{8}$  inches (41 mm) long, spaced 8 inches (203 mm) on center along the wall perimeter, 12 inches (305 mm) on center vertically and 16 inches (406 mm) on center horizontally. The joints must be treated and taped, and the screw heads must be covered with joint compound, in accordance with ASTM C 840 or GA-216. Where the panels are used as exterior walls, the exterior gypsum board must be gypsum sheathing.

#### 4.2.8 One Hour Fire-resistance-rated Floor-Ceiling Assembly:

Premier Type S panels with 7 $\frac{1}{4}$ -inch-thick (184 mm) EPS cores laminated between two sheets of  $\frac{7}{16}$ -inch-thick (11 mm) OSB installed in accordance with this section of this report are a one-hour, fire-resistance-rated floor-ceiling assembly.

Panels must be connected at the edge joints by inserting 3 $\frac{1}{2}$ -inch-wide (89 mm) OSB splines into the prerouted slots in the EPS and fastening to the OSB facers of the panels with 1 $\frac{1}{8}$  inch-long (29 mm) drywall screws spaced 6 inches (152 mm) on center.

The bottom side of the panel must be covered with a base layer of  $\frac{5}{8}$ -inch-thick (16 mm) Type X gypsum wallboard complying with ASTM C 36 or C 1396 applied with the joints parallel to the spline joints offset by 24 inches (610 mm), with 1 $\frac{1}{4}$ -inch-long (32 mm) Type S drywall screws spaced 12 inches (305 mm) on center in rows 24 inches (610 mm), on center. A face layer of  $\frac{5}{8}$ -inch-thick (16 mm) Type X gypsum wallboard must be applied at right angles to the base layer with 2-inch-long (51 mm) Type S drywall screws spaced 12 inches (305 mm) on center in rows spaced 16 inches (406 mm) on center. The joints of the face layer of gypsum board must be treated and taped, and the screw heads must be covered with joint compound, in accordance with ASTM C 840 or GA-216.

The maximum allowable superimposed load is 40 psf (1915 Pa) and the maximum allowable span is 12 feet (3658 mm).

#### 5.0 CONDITIONS OF USE

The Premier Structural Sandwich Panels described in this report comply with, or are suitable alternatives to what is specified in, those codes listed in Section 1.0 of this report, subject to the following conditions:

- 5.1 The panels must be fabricated, identified and installed in accordance with this report and the manufacturer's published installation instructions. In the event of a conflict between this report and the manufacturer's published installation instructions, this report governs.
- 5.2 Design loads to be resisted by the panels must be determined in accordance with the applicable code, and must be equal to, or less than, the values given in Tables 2 through 11 of this report.
- 5.3 All construction documents specifying the building panels described in this report must comply with the design limitations of this report. Design calculations and details for the specific applications must be furnished to the code official verifying compliance with this report and applicable codes. The documents must be prepared by a registered design professional where required by the statutes of the jurisdiction in which the project is to be constructed.
- 5.4 All floor-to-wall and roof-to-wall details must be designed such that gravity loads are applied to the wall panels as a uniform concentric axial load over the entire wall panel thickness.
- 5.5 Connection and attachments of the panel are outside the scope of this report and must be addressed in the design calculations and details.
- 5.6 When used as shear walls under the IBC or IRC, the panels are recognized for use in Seismic Design Categories A, B and C.
- 5.7 The foam plastic insulation of the panels must be separated from the interior of the building with a thermal barrier, installed in accordance with Section 4.2.3 of this report.

- 5.10** Use of the floor panels is limited to residential occupancies.
- 5.11** Use of the panels is limited to Type V construction.
- 5.12** For structures regulated under the IBC and IRC, use of the foam plastic in areas subject to damage from termites must be in accordance with IBC Section 2603.8 and IRC Section R320.5.
- 5.13** For structures regulated under the SBC, the panels must not be placed within 6 inches (152 mm) of earth where the hazard of termite damage is very heavy, in accordance with SBC Figure 2304.1.4, without an approved method of protecting the foam plastic and structure from subterranean termite damage.
- 5.14** The panels shall be installed such that the panel facings are protected against decay and termites in accordance with IBC Sections 2304.11.2.2 and 2304.11.2.6, IRC Sections R319 and R320, BNBC Section 2311.4.2, SBC Section 2304 and UBC Section 2306.8, as applicable.
- 5.15** The panels and their attachments must be subject to inspection by the code official prior to covering with an approved water resistive barrier or roof covering.
- 5.16** For installations of the roof panels, justification must be submitted to the code official demonstrating that the panels with the roof covering comply as a Class A, B, or C roof assembly, as required by IBC Section 2603.6, UBC Section 2602.5.3, or SBC Section 2603.7, as applicable, with the classification complying with the

minimum classification requirements for the building.

- 5.17** The panels are produced in Fife, WA; Phoenix, AZ; and Cottonwood, MN under a quality control program with inspections by Underwriters Laboratories Inc. (AA-668).

## 6.0 EVIDENCE SUBMITTED

- 6.1** Data in accordance with the ICC Acceptance Criteria for Sandwich Panels (AC04), dated June 2007 (editorially revised April 2008).
- 6.2** Reports of tests conducted in accordance with ASTM E119.
- 6.3** Report of a room corner fire test in accordance with UL 1715 or UBC Standard 26-3.
- 6.4** Report of a diaphragm load test.
- 6.5** Reports of header load tests.

## 7.0 IDENTIFICATION

The panels must have a label containing the name and address of Premier Building Systems, the product panel number, the plant identification number (see Table 1), the thickness and density of the panel core, the evaluation report number (ESR-1882) and the label of the inspection agency (Underwriters Laboratories, Inc.). The I-joint splines are labeled with the company name of Superior Wood Systems and the name of the inspection agency (PFS Corporation).

**TABLE 1—MANUFACTURING LOCATIONS**

LOCATIONS OF PREMIER INDUSTRIES, INC / d.b.a.	LOCATION NUMBERS FOR PRODUCT IDENTIFICATION
Premier Building Systems 4609 70th Ave. E Fife, Washington 98424	PB-31
Premier Building Systems 3434 West Papago Street Phoenix, Arizona 85009-6733	PB-32
Extreme Panel Technologies, Inc. 475 East 4th Street North Cottonwood, MN 56229	EPT-01

**TABLE 2—TYPE S PANELS<sup>1,2,3</sup>**  
**MAXIMUM ALLOWABLE TRANSVERSE LOADS(psf)**

PANEL CORE THICKNESS (inches)	DEFLECTION	PANEL SPAN								
		8 ft	10 ft	12 ft	14 ft	16 ft	18 ft	20 ft	22 ft	24 ft
3 <sup>1</sup> / <sub>2</sub> <sup>4</sup>	L <sub>/360</sub>	38	28	21	16	10	----	----	----	----
	L <sub>/240</sub>	54	43	32	24	16	----	----	----	----
	L <sub>/180</sub>	61*	57	45	34	21	----	----	----	----
5 <sup>1</sup> / <sub>2</sub> <sup>5</sup>	L <sub>/360</sub>	49	38	30	24	18	14	11	----	----
	L <sub>/240</sub>	78	57	45	32	28	22	16	----	----
	L <sub>/180</sub>	80*	60*	46*	40*	34*	29	21	----	----
7 <sup>1</sup> / <sub>4</sub> <sup>6</sup>	L <sub>/360</sub>	59	75	41	34	26	20	15	13	11
	L <sub>/240</sub>	84	75*	60	50	39	31	23	19	18
	L <sub>/180</sub>	85*	75*	69*	60*	50*	41	31	27	24
9 <sup>1</sup> / <sub>4</sub> <sup>7</sup>	L <sub>/360</sub>	78	64	53	41	33	27	22	20	17
	L <sub>/240</sub>	86*	65*	57*	51*	46*	41	34	29	25
	L <sub>/180</sub>	86*	65*	57*	51*	46*	42	39*	37*	34
11 <sup>1</sup> / <sub>4</sub> <sup>7</sup>	L <sub>/360</sub>	94*	75	51	49	47	38	28	24	21
	L <sub>/240</sub>	94*	76*	59*	55*	51*	45*	39*	36	31
	L <sub>/180</sub>	94*	76*	59*	55*	51*	45*	39*	36*	33*

For SI: 1 inch = 25.4 mm, 1 psf = 47.9 Pa, 1 foot = 304.8 mm.

<sup>1</sup>Floor panels must have a minimum <sup>3</sup>/<sub>4</sub> inch thick top skin or a minimum <sup>7</sup>/<sub>16</sub> inch thick top skin overlaid with minimum <sup>7</sup>/<sub>16</sub> inch thick finish flooring perpendicular to the panels.

<sup>2</sup>The panels must be continuously supported at each end of the panel span with continuous supports providing a 1<sup>1</sup>/<sub>2</sub>-inch minimum bearing length.

<sup>3</sup>Allowable loads with an asterisk, \*, indicates a capacity based on the average peak test load divided by 3.

<sup>4</sup><sup>3</sup>/<sub>2</sub>-inch thick core panels must be limited to a maximum span of 10 feet when used in roof applications.

<sup>5</sup><sup>5</sup>/<sub>2</sub> inch thick core panels must be limited to a maximum span of 12 feet when used in roof applications.

<sup>6</sup><sup>7</sup>/<sub>4</sub> inch thick core panels must be limited to a maximum span of 14 feet when used in roof applications.

<sup>7</sup><sup>9</sup>/<sub>4</sub> inch and 11<sup>1</sup>/<sub>4</sub> inch thick core panels must be limited to a maximum span of 16 feet when used in roof applications.

**TABLE 3—TYPE I PANELS<sup>1,2,3</sup>**  
**MAXIMUM ALLOWABLE TRANSVERSE LOADS (psf)**

PANEL CORE THICKNESS (inches)	DEFLECTION	PANEL SPAN									
		4 ft <sup>4</sup>	8 ft	10 ft	12 ft	14 ft	16 ft	18 ft	20 ft	22 ft	24 ft
7 <sup>1</sup> / <sub>4</sub> <sup>5</sup>	L <sub>/360</sub>	122	134	92	60	48	40	29	21	----	----
	L <sub>/240</sub>	318*	148*	107*	90	70	58	42	31	----	----
	L <sub>/180</sub>	318*	148*	107*	92*	85	77	48	40	----	----
9 <sup>1</sup> / <sub>4</sub> <sup>6</sup>	L <sub>/360</sub>	185	164*	124*	71	66	60	48	34	29	24
	L <sub>/240</sub>	318*	164*	124*	107*	96*	84*	70	49	43	36
	L <sub>/180</sub>	318*	164*	124*	107*	96*	84*	76*	69	56	47
11 <sup>1</sup> / <sub>4</sub> <sup>6</sup>	L <sub>/360</sub>	244	143*	103*	84	83	77*	61	42	37	32
	L <sub>/240</sub>	318*	143*	103*	93*	85*	77*	68*	59*	54*	47
	L <sub>/180</sub>	318*	143*	103*	93*	85*	77*	68*	59*	54*	49*

For SI: 1 inch = 25.4 mm, 1 psf = 47.9 Pa, 1 foot = 304.8 mm.

<sup>1</sup>Floor panels must have a minimum <sup>3</sup>/<sub>4</sub> inch thick top skin or a minimum <sup>7</sup>/<sub>16</sub> inch thick top skin overlaid with minimum <sup>7</sup>/<sub>16</sub> inch thick finish flooring perpendicular to the panels.

<sup>2</sup>The panels must be supported at each end of the panel span with continuous supports providing a 1<sup>1</sup>/<sub>2</sub>-inch minimum bearing length.

<sup>3</sup>Allowable loads with an asterisk, \*, indicates a capacity based on the average peak test load divided by 3.

<sup>4</sup>Panels spanning 4 feet must be a minimum of 8 feet long spanning a minimum of two 4 foot spans. No single span conditions shall be permitted.

<sup>5</sup><sup>7</sup>/<sub>4</sub>-inch thick core panels must be limited to a maximum span of 16 feet when used in roof applications.

<sup>6</sup><sup>9</sup>/<sub>4</sub> and 11<sup>1</sup>/<sub>4</sub>-inch thick core panels must be limited to a maximum span of 20 feet when used in roof applications.

**TABLE 4—TYPE L PANELS<sup>1,2,3</sup>**  
**MAXIMUM ALLOWABLE TRANSVERSE LOADS (psf)**

PANEL CORE THICKNESS (inches)	DEFLECTION	PANEL SPAN									
		4 ft <sup>4</sup>	8 ft	10 ft	12 ft	14 ft	16 ft	18 ft	20 ft	22 ft	24 ft
3 <sup>1</sup> / <sub>2</sub> <sup>5</sup>	L <sub>/360</sub>	98	45	32	24	16	11	----	----	----	----
	L <sub>/240</sub>	215	67	47	34	24	16	----	----	----	----
	L <sub>/180</sub>	298*	90	61	44	34	22	----	----	----	----
5 <sup>1</sup> / <sub>2</sub> <sup>6</sup>	L <sub>/360</sub>	241	128	57	41	33	25	20	15	----	----
	L <sub>/240</sub>	288*	182*	86	60	49	37	29	22	----	----
	L <sub>/180</sub>	288*	182*	112*	79	65	49	39	29	----	----
7 <sup>1</sup> / <sub>4</sub> <sup>7</sup>	L <sub>/360</sub>	241	168	80	65	54	42	33	24	----	----
	L <sub>/240</sub>	288*	188*	126	99	81	61	49	34	----	----
	L <sub>/180</sub>	288*	188*	133*	117*	105	80	62	44	----	----
9 <sup>1</sup> / <sub>4</sub> <sup>8</sup>	L <sub>/360</sub>	274	188*	116	100	80	62	47	35	32	28
	L <sub>/240</sub>	326*	188*	147*	134*	120	92	70	52	46	41
	L <sub>/180</sub>	326*	188*	147*	134*	121*	108*	93	68	61	53
11 <sup>1</sup> / <sub>4</sub> <sup>8</sup>	L <sub>/360</sub>	327*	188*	167*	140	116	90	75	57	47	36
	L <sub>/240</sub>	327*	188*	167*	153*	132*	110*	97*	83*	69	53
	L <sub>/180</sub>	327*	188*	167*	153*	132*	110*	97*	83*	83*	70

For SI: 1 inch = 25.4 mm, 1 psf = 47.9 Pa, 1 foot = 304.8 mm.

<sup>1</sup>Floor panels must have a minimum <sup>3</sup>/<sub>4</sub> inch thick top skin or a minimum <sup>7</sup>/<sub>16</sub> inch thick top skin overlaid with minimum <sup>7</sup>/<sub>16</sub> inch thick finish flooring perpendicular to the panels.

<sup>2</sup>The panels must be supported at each end of the panel span with continuous supports providing a 1<sup>1</sup>/<sub>2</sub>-inch minimum bearing length.

<sup>3</sup>Allowable loads with an asterisk, \*, indicates a capacity based on the average peak test load divided by 3.

<sup>4</sup>Panels spanning 4 feet shall be a minimum of 8 feet long spanning a minimum of two 4 foot spans. No single span conditions must be permitted.

<sup>5</sup>3<sup>1</sup>/<sub>2</sub>-inch thick core panels must be limited to a maximum span of 10 feet when used in roof applications.

<sup>6</sup>5<sup>1</sup>/<sub>2</sub>-inch thick core panels must be limited to a maximum span of 14 feet when used in roof applications.

<sup>7</sup>7<sup>1</sup>/<sub>4</sub>-inch thick core panels must be limited to a maximum span of 18 feet when used in roof applications.

<sup>8</sup>9<sup>1</sup>/<sub>4</sub> and 11<sup>1</sup>/<sub>4</sub>-inch thick core panels shall be limited to a maximum span of 20 feet when used in roof applications.

**TABLE 5—TYPE S PANELS**  
**MAXIMUM ALLOWABLE AXIAL LOADS (plf)<sup>1</sup>**

PANEL CORE THICKNESS (inches)	PANEL SPAN					
	8 ft	10 ft	12 ft	16 ft	20 ft	24 ft
3 <sup>1</sup> / <sub>2</sub>	3500	2555	2450	2120	----	----
5 <sup>1</sup> / <sub>2</sub>	4250	4040	3375	3920	2815	----
7 <sup>1</sup> / <sub>4</sub>	4915	4325	4475	4195	3495	3065
9 <sup>1</sup> / <sub>4</sub>	4200	4200	4200	4200	3389	3247
11 <sup>1</sup> / <sub>4</sub>	3890	3890	3890	3890	3890	3333

For SI: 1 inch = 25.4 mm, 1 plf = 14.6 N/m, 1 foot = 304.8 mm.

<sup>1</sup>For the allowable axial load on the fire-resistance-rated assembly, see Section 4.2.6.

**TABLE 6—TYPE L PANELS**  
**MAXIMUM ALLOWABLE AXIAL LOADS (plf)<sup>1</sup>**

PANEL CORE THICKNESS (inches)	PANEL SPAN					
	8 ft	10 ft	12 ft	16 ft	20 ft	24 ft
3 <sup>1</sup> / <sub>2</sub>	4725	3905	3095	2350	----	----
5 <sup>1</sup> / <sub>2</sub>	5850	5890	4280	4310	2933	----
7 <sup>1</sup> / <sub>4</sub>	6850	6110	5555	5180	4835	4080
9 <sup>1</sup> / <sub>4</sub>	5470	5470	5470	5470	5470	4250
11 <sup>1</sup> / <sub>4</sub>	4500	4333	4167	3750	3750	3333

For SI: 1 inch = 25.4 mm, 1 plf = 14.6 N/m, 1 foot = 304.8 mm.

<sup>1</sup>For the allowable axial load on fire-resistance-rated assembly, see Section 4.2.7.

**TABLE 7—TYPE S AND L PREMIER WALL PANELS  
MAXIMUM ALLOWABLE AXIAL POINT LOADS (lbs)**

	1½ inch Minimum Bearing Width	3 inch Minimum Bearing Width
Standard Detail	2040	2450
Additional Cap Plate <sup>1</sup>	4030	4680

For **SI**: 1 inch = 25.4 mm, 1 lb. = 4.45 N.

<sup>1</sup>See Figure 14 of this report.

**TABLE 8—CONTINUOUS HEADER WITHOUT SPLINES MAXIMUM ALLOWABLE LOADS (plf)**

HEADER DEPTH (inches)	DEFLECTION	HEADER SPAN			
		4 ft	6 ft	8 ft	10 ft
12	$L/360$	740	385	229	142
	$L/240$	740	385	229	142
	$L/180$	740	385	229	142
18	$L/360$	798	574	385	311
	$L/240$	798	574	385	311
	$L/180$	798	574	385	311
24	$L/360$	886	629	429	361
	$L/240$	886	629	429	361
	$L/180$	886	629	429	361

For **SI**: 1 inch = 25.4 mm, 1 plf = 14.6 N/m, 1 foot = 304.8 mm.

**TABLE 9—HEADER WITH OSB SPLINES MAXIMUM ALLOWABLE LOADS (plf)**

HEADER DEPTH (inches)	DEFLECTION	HEADER SPAN			
		4 ft	6 ft	8 ft	10 ft
12	$L/360$	345	245	156	99
	$L/240$	450	295	190	125
	$L/180$	630	382	236	153
18	$L/360$	705	388	255	235
	$L/240$	750	482	302	281
	$L/180$	750	482	302	281
24	$L/360$	700	555	368	350
	$L/240$	895	555	368	350
	$L/180$	895	555	368	350

For **SI**: 1 inch = 25.4 mm, 1 plf = 14.6 N/m, 1 foot = 304.8 mm.

**TABLE 10—PREMIER WALL PANELS<sup>1,2</sup>  
MAXIMUM ALLOWABLE SHEAR WALL LOADS**

PANEL TYPE	MINIMUM OSB FACE THICKNESS	ATTACHMENTS				RACKING SHEAR (plf)
		2x Framing		Splines		
		Fasteners	Spacing	Fasteners	Spacing	
L or S	$7/16$ inch	8d box nail	6 inches	8d nail	6 inches	300
S	$7/16$ inch	8d box nail	4 inches	#6 Screw <sup>3</sup>	4 inches	600 <sup>4</sup>

For **SI**: 1 inch = 25.4 mm, 1 plf = 14.6 N/m.

<sup>1</sup>Framing lumber must be a minimum of Douglas fir-larch having a minimum specific gravity of 0.50.

<sup>2</sup>The maximum panel height-to-width ratio shall be 1:1.

<sup>3</sup>Screws are #6 x 1¼ inch Type W drywall screws.

<sup>4</sup>Two top plates are required with fasteners attaching the OSB to both plates.

**TABLE 11—PREMIER PANELS<sup>1</sup>**  
**MAXIMUM ALLOWABLE DIAPHRAGM LOADS**

MINIMUM OSB FACE THICKNESS (inches)	ATTACHMENTS						SHEAR (plf)
	Diaphragm Perimeter <sup>2</sup>		Panel Joints - Top Only <sup>3</sup>		Panel Joints - Top & Bottom <sup>4</sup>		
	Fasteners	Spacing	Fasteners	Spacing	Fasteners	Spacing	
$\frac{7}{16}$	PBS Screw <sup>5</sup>	12 inches	8d nail	3 inches	8d nail	6 inches	435 <sup>6</sup>
$\frac{7}{16}$	PBS Screw <sup>5</sup>	3 inches	8d nail	2 inches	8d nail	4 inches	540 <sup>7</sup>
$\frac{7}{16}$	PBS Screw <sup>5</sup>	2 inches	8d nail	1 $\frac{1}{2}$ inches	8d nail	3 inches	750 <sup>8</sup>

For **SI**: 1 inch = 25.4 mm, 1 plf = 14.6 N/m.

<sup>1</sup>The maximum panel length-to-width ratio shall be 4½:1.

<sup>2</sup>See Figure 15 of this report.

<sup>3</sup>See Figure 16 of this report.

<sup>4</sup>See Figure 17 of this report.

<sup>5</sup>See description of PBS screw in Section 3.2.5. The screws must have a minimum penetration of 2-inches into panel supports having a minimum specific gravity of 0.43.

<sup>6</sup>The deflection of the 36 foot span for the diaphragm at 425 plf was 0.41 inch.

<sup>7</sup>The deflection of the 36 foot span for the diaphragm at 510 plf was 0.37 inch.

<sup>8</sup>The deflection of the 36 foot span for the diaphragm at 750 plf was 0.37 inch.

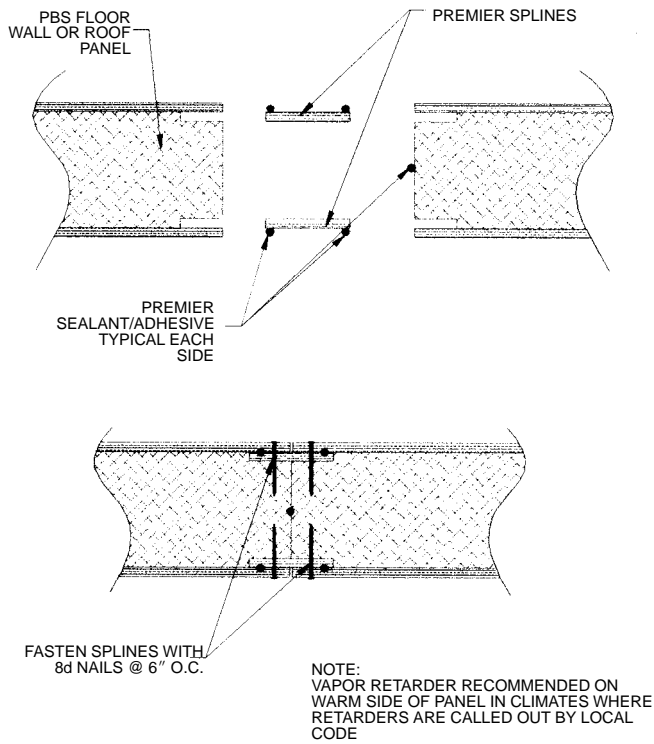

FIGURE 1

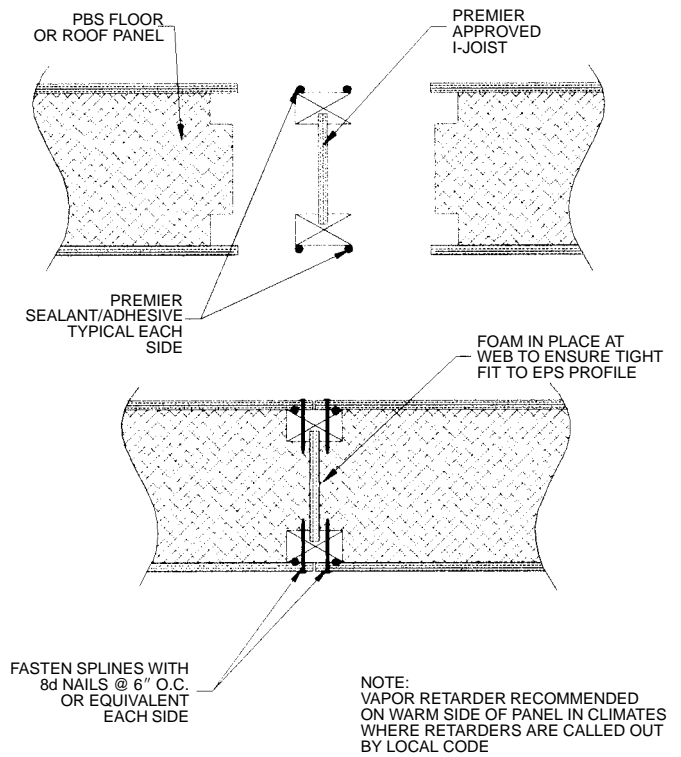

FIGURE 2

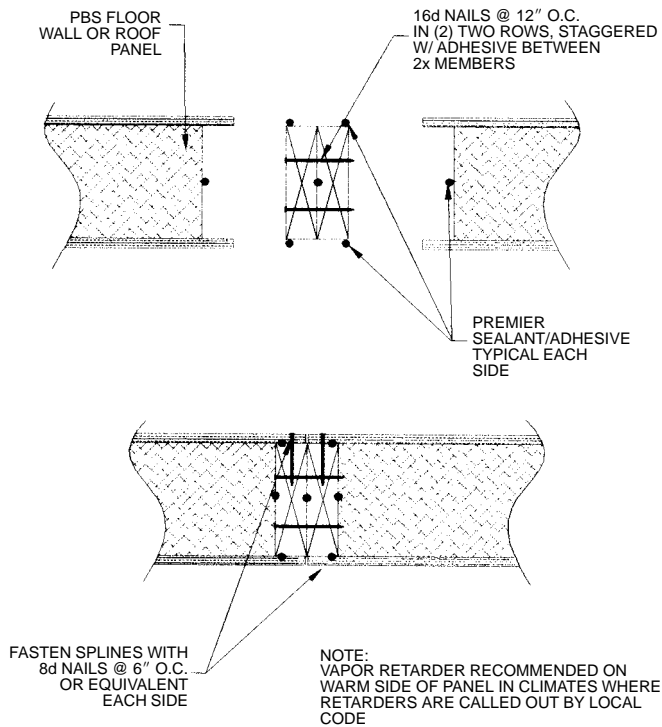

FIGURE 3

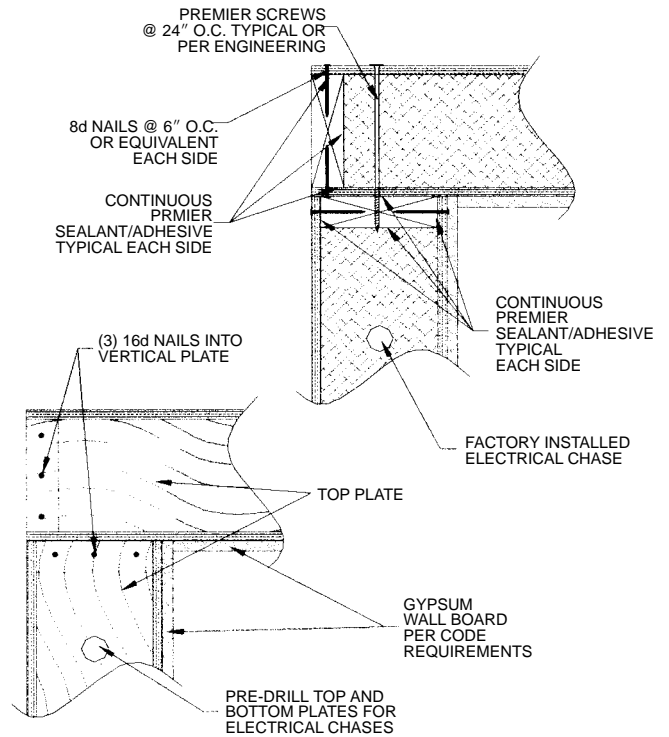

FIGURE 4

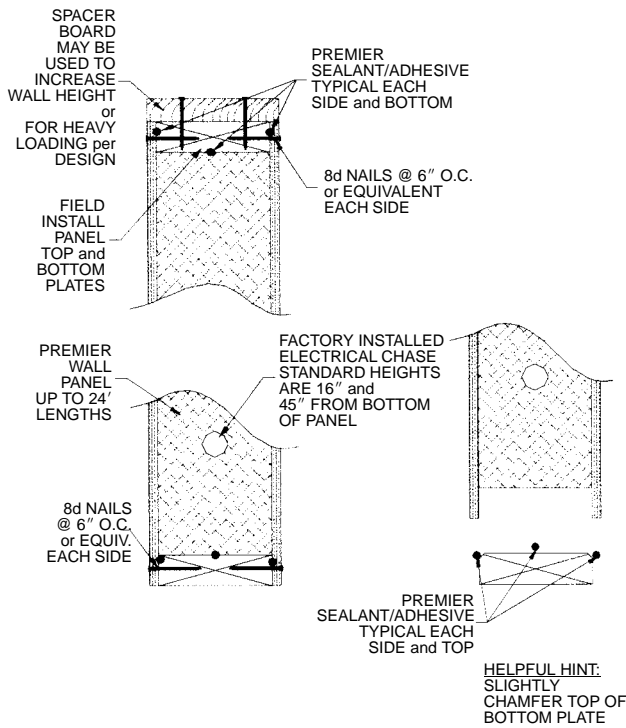

FIGURE 5

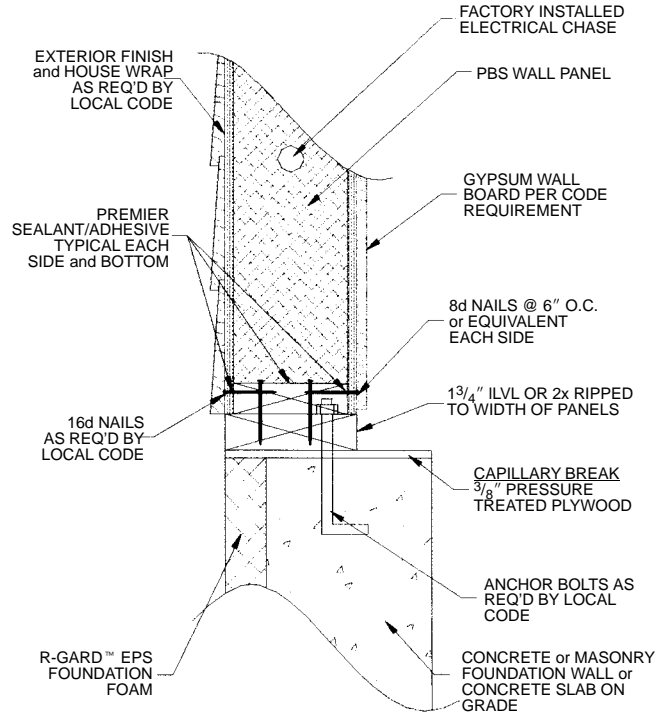

FIGURE 6

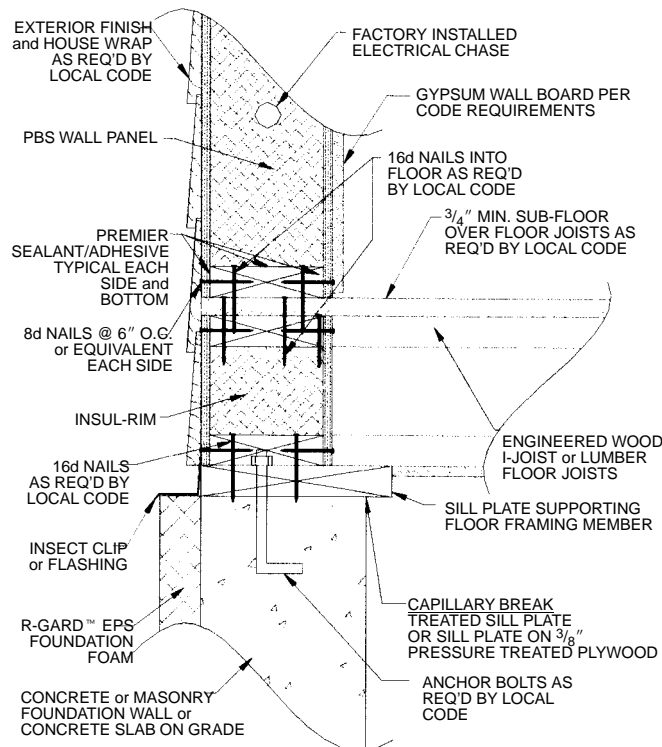

FIGURE 7

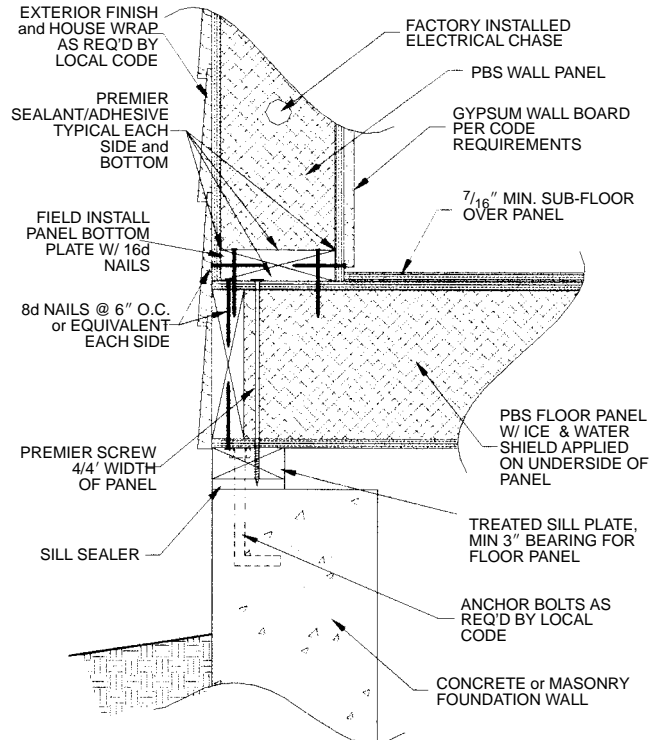

FIGURE 8

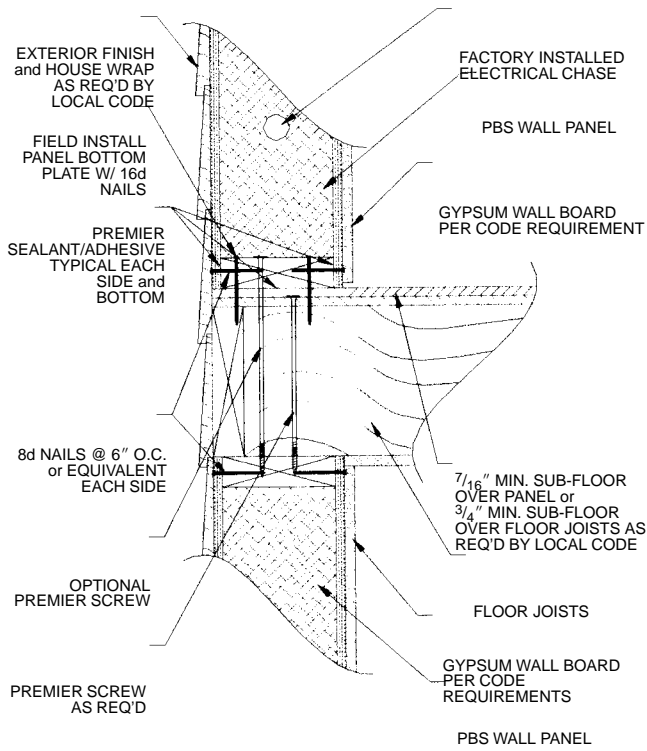

FIGURE 9

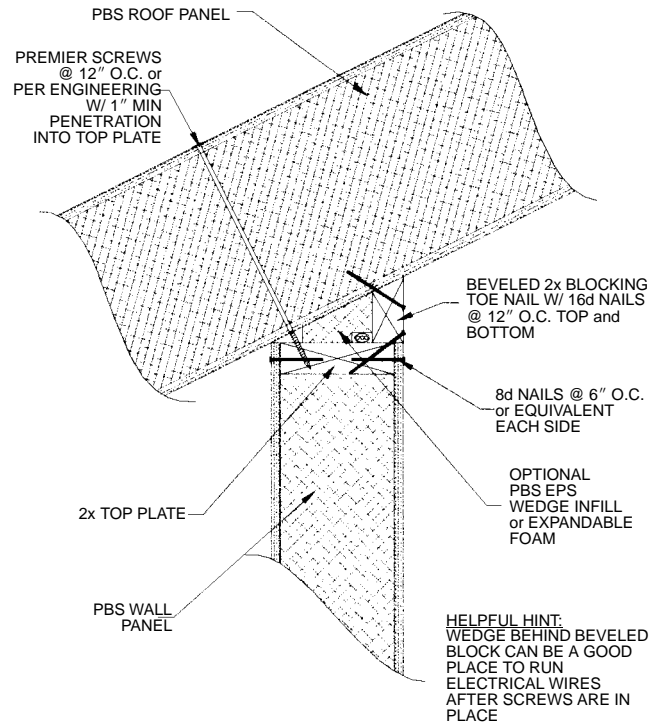

FIGURE 10

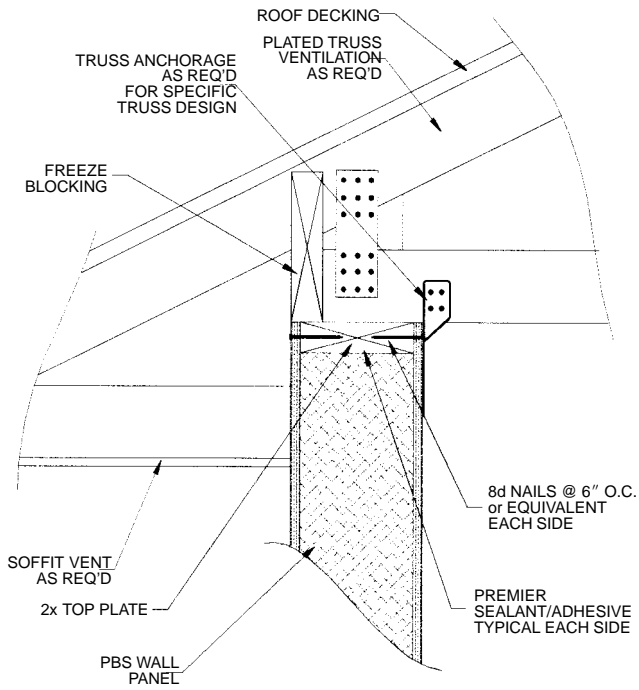

FIGURE 11

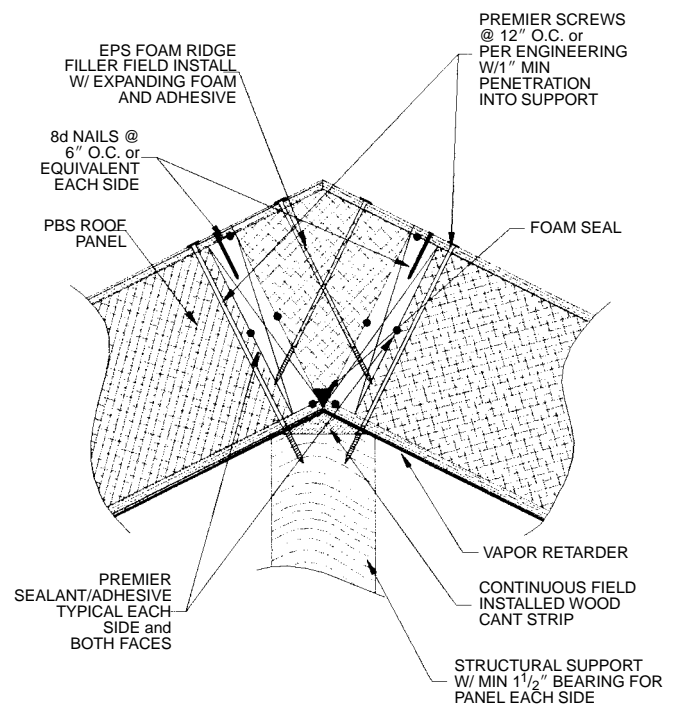

FIGURE 12

SEE LOAD DESIGN CHARTS FOR ALLOWABLE HEADER LOADS

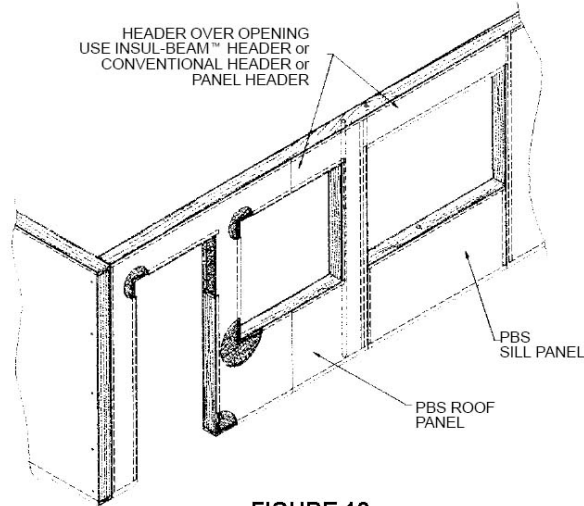

FIGURE 13

**Premier Cap Plate** - standard 2x lumber, 1 1/8" OSB or 1 1/8" OSL (Rimboard), which has been ripped to the overall width of the wall panel so that the OSB skins of the panel are covered by the ripped material

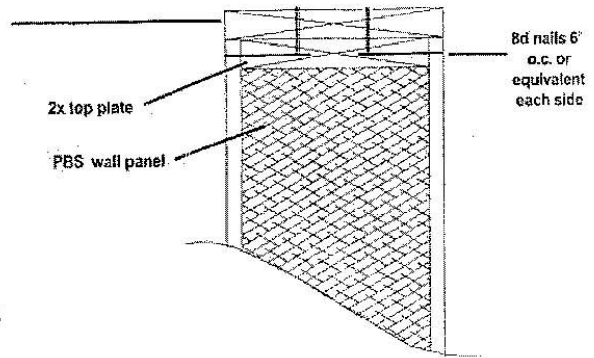

FIGURE 14

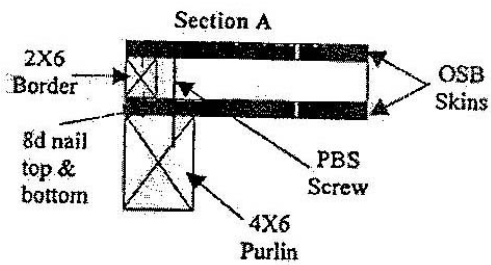

FIGURE 15

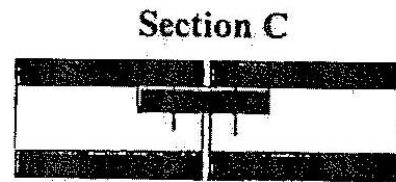

FIGURE 16

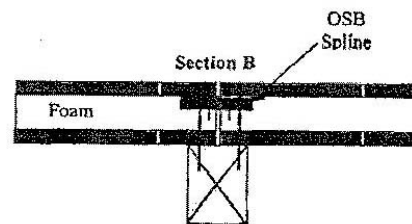

FIGURE 17