



ENGINEERING & TECHNICAL SERVICES, INC.

STRUCTURAL ENGINEERING & DESIGN

27121 469th Ave.
Teo, SD 57064-8100
(605) 498-1290 OFFICE
(605) 498-1299 FAX

COPYRIGHT, 2005, ENGINEERING AND TECHNICAL SERVICES, INC.

4' EXTREME FOUNDATION PANELS

For House Crawl Space
On Concrete Footings

1. The type of soil is a factor in determining foundation construction details such as footing design, backfill, and drainage provisions. Soils are classified by their composition and how they drain. Soil classifications for most areas are listed in the standard series of soil surveys published by the U.S. Department of Agriculture's Soil Conservation Service. Extreme's Foundation panels may be built in Group I, II, or III soils. Group IV soils are generally not recommended for Extreme's Foundation panels, unless special measures are taken. For building sites in areas where expansive clay soils in Group II, III or IV occur, a licensed soils engineer should be consulted to determine modifications required for foundation footings, drainage, soil moisture control, and back fill around the foundation. In such cases, special design considerations and construction details may be needed to avoid soil expansion or shrinkage which might otherwise affect foundation and floor performance. For crawl space type foundations, a sump, draining to daylight or into a storm sewer is recommended for all soil types. (Refer to attached "Table 1-Types of soils and related design properties" from Southern Pine Council PWF Design & Construction Guide. www.southernpine.com).
2. Granular materials are recommended for footings under Extreme's Foundation panels, but continuous poured concrete may also be used for footings. Granular materials are to be used for a portion of the backfill to provide an optimum drainage system. The granular material may be crushed stone, gravel or sand, and must be clean and free of silt, clay, and organic material. Limitations are:
 - Maximum of 1/2" for crushed stone
 - Maximum of 3/4" for gravel
 - Minimum of 1/16" for sand
3. Footings need to be placed on undisturbed soil and the footing excavation should extend below the frost line. To achieve proper frost protection for low backfill heights, either the footing needs to be excavated to the proper depth or refer to section R403.3 of the IRC code book or refer to the "Revised Builder's Guide to Frost Protected Shallow Foundations". This can be determined for site specific situations.

4. For concrete footings, typically minimum size of 8" thick by 16" wide and a minimum compressive strength of 2500 lbs., it is recommended to place the footing on 4" of granular material to maintain continuity of the drainage system, otherwise 3" drains at 6' o.c. must be provided through the concrete footings. In Group I and II soils, place a minimum of 4" of granular fill and for Group III soils use a minimum of 6" of granular fill in the crawl space area for proper drainage to a Sump pit located in the interior or exterior of the foundation. With Group I soils, granular material can be used for drainage on the outside of the foundation as long as it is covered by a 6 mil poly sheeting or water permeable filter fabric to prevent soil from washing into the footing. In Group II and III soils it is recommended that a 4" perforated tile be placed at same grade level as the footing and covered with a filter cloth to keep the perforations open. This tile along with the granular bed in the crawl space area needs to be sloped toward the sump to drain properly. Alternative drainage systems like Form-A-Drain can be used for both the concrete forms and the drainage system for the concrete footings. An automatic electric sump pump will be needed if the sump cannot be drained by gravity to daylight or to a storm sewer system.
5. Anchor the .60 CCA treated 2x8 to the concrete footing using 1/2" x 8" galvanized anchor bolts 4' o.c. and located within 12" from the end of each plate section. Remember to set the plates in 5/8" from outer dimensions of the structure to allow for exterior skin of panel to fit on the outside of the plate.
6. Install Extreme's Foundation panel according to the panel layout drawing provided. Use Panel Adhesive/Sealant for all wood to wood connections. Use the expandable foam with gun for all wood to foam or foam to foam connections. Refer to page 18 of Extreme Panel's Construction Detail Manual for placement of these products. Nail all panel connections using 2" stainless steel (type 304 or 316) ring shank nails 8" o.c.. These materials are supplied by Extreme Panels. Any other alternative products need to be approved by Extreme Panels. Note: If a pneumatic nailer is used, do not drive the heads of the nails in any deeper than 1/8". Top plates (typically not treated) are to be installed with the ends of the top plates staggered to not fall on the seam of a panel vertical connection.
7. Seal exterior joints in the plywood using 4" SIP Flashing which is supplied by Extreme Panels. The Panel Adhesive/Sealant can also be used.
8. Floor systems can either be stacked on top of the foundation or can be set to the inside of the foundation. There is to be a minimum clearance in the crawl space area of 18" to the floor system and 12" to any supporting member for the floor. For stacking the floor and you are using Extreme's Insulated Rimboard, refer to page 33 of Extreme Panel's Construction Detail Manual for installation guidelines. If an alternative rimboard is used, follow that products installation manual. Set the floor system that has been designed for the structure according to their layout. Fasten the floor joists to the top plate of the panel using (3) #9x3" screws or (3) 16d nails. If you are setting the floor on the inside of the foundation, the top of the joists are even with the top plate of foundation. The joists are supported by either framing hangers or on a ledger built on the inside of the foundation. Floor decking is to run over the top of the foundation to the outside edge of the panel. For joists that are running parallel to the foundation walls a continuous run of 2x6's at 10' o.c. the entire length of the structure. These are to be fastened to blocking placed on the rimboard and the top plate of the panel using #9x3" screws. Refer to page 39 of Extreme Panel's Construction Detail Manual for placement of bracing. Also refer to the manufacturer guidelines of the floor joist. Bracing required by the manufacturer can be incorporated with bracing required for the foundation walls.

(It does not matter where on the panel seams these are located). Refer to panel layout to place solid blocking required through floor system for point loads from structure above. Interior supports for floor framing may be posts and girder beams or unshathed .60 CCA treated 2x6 lumber built wall. For lumber built wall, align studs w/ joist or use double top plates. Wall can be placed on concrete footing designed the same as exterior foundation or placed on a granular footing with a 2x10 .60 CCA treated base plate. For high concentration loads, footing size may have to be increased.

9. Below grade moisture barrier: 6 mil poly is to be applied over the below grade exterior portion of the foundation and over the granular material on the inside area of the crawl space. A single layer is adequate, but 2 layers is suggested for extra protection on the exterior when backfilling. Poly is to be draped over the footing, but is not to extend over the drainage tile. Joints in the poly are to be lapped a minimum of 6" and sealed with Panel Adhesive/Sealant or equivalent. The top edge of the poly is to be bonded to the panel to create a seal. This is to be achieved by using at least a 12" treated plywood strip or other strips can be used for architectural treatment. Before strip is installed, a continuous seal of adhesive is to be applied between the wall and strip. The strip needs to extend at least 9" below grade.
10. Backfilling: Backfilling is not permitted until floor system has been constructed. A maximum backfill height of 3'-4" is permitted and a minimum backfill height of 12" is permitted. Granular material is to be used for backfill. Backfill a distance of 1'-4" out from the wall and 2/3 the height of the total backfill height. Granular material is then to be covered with either 30 pound asphalt paper or 6 mil poly to allow for water seepage while avoiding infiltration of fine soils. The remaining of the backfill can use the same type of soil as was removed during the excavation. Finish grade is to slope a 1/2" per foot a minimum of 6'-0" from structure.
11. Air quality in the crawl space area needs to be addressed. This can be achieved by circulating the air using a mechanical ventilation system. Ventilation can be incorporated with the air exchange system or heating system. This would need to be provided at the rate of 1.0 cfm for each 50 square feet of underfloor space and ground surface is covered with 6 mil poly.

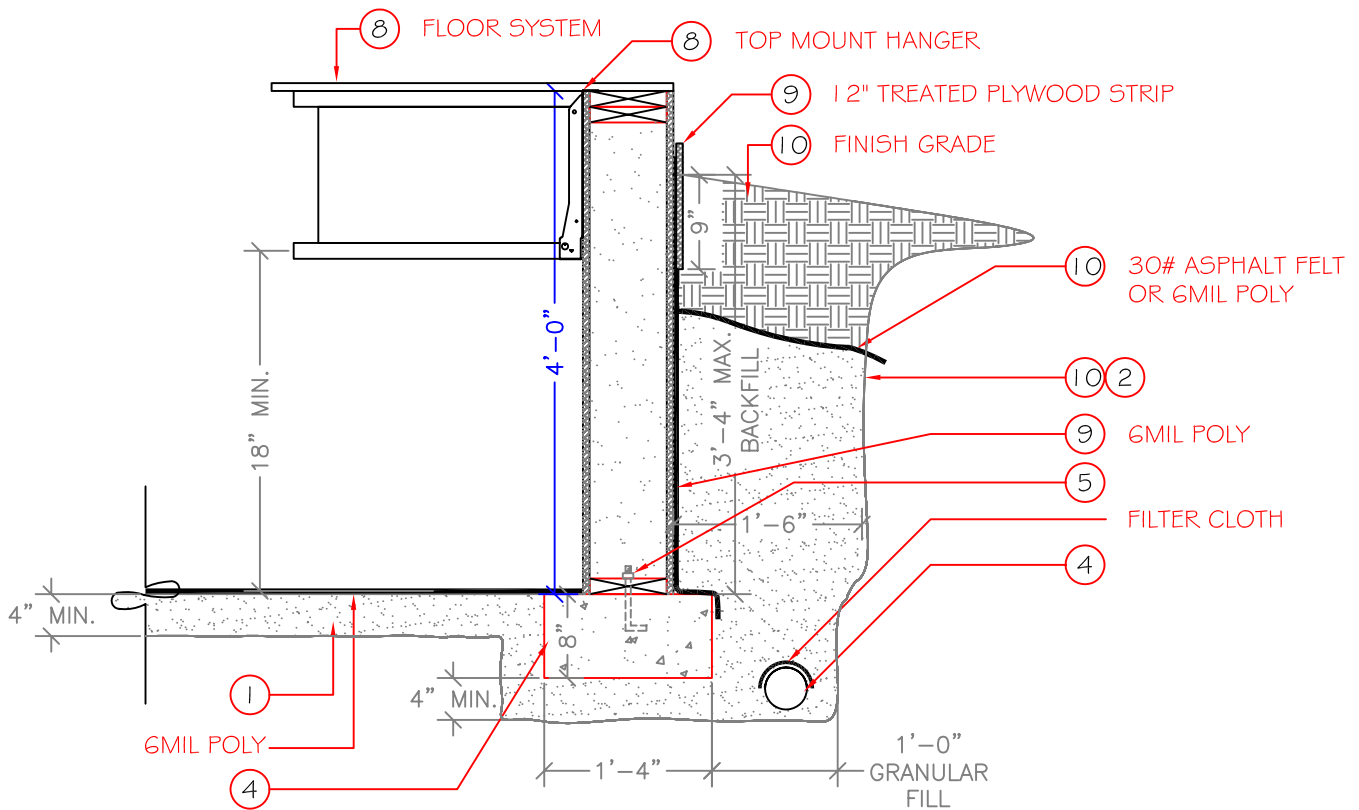
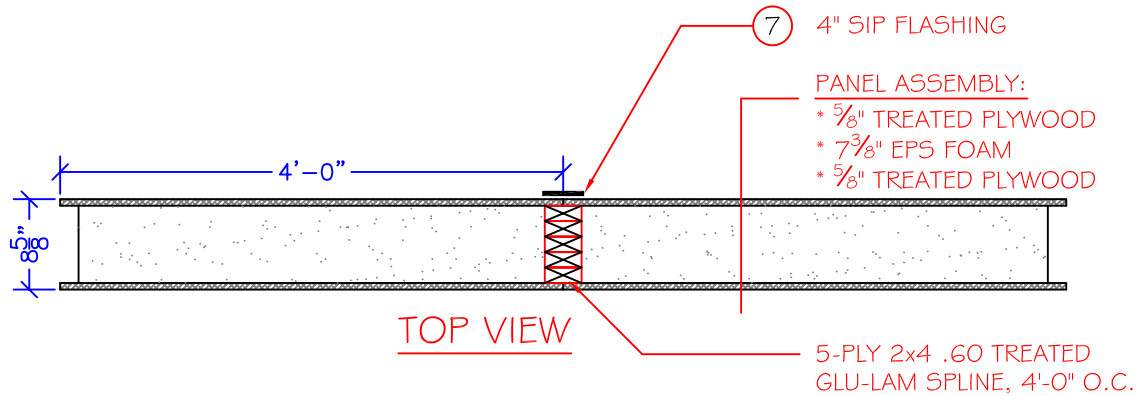

DETAIL TITLE: BELOW GRADE 8" CRAWL SPACE PANEL
 FOOTING TYPE: CONCRETE FOOTING
 UPDATED: 05/18/05



ENGINEERING & TECHNICAL SERVICES, INC.
 STRUCTURAL ENGINEERING & DESIGN

27121 469th Ave.
 Teo, SD 57064-8100
 (605) 498-1290 OFFICE
 (605) 498-1299 FAX

COPYRIGHT, 2005, ENGINEERING AND TECHNICAL SERVICES, INC.

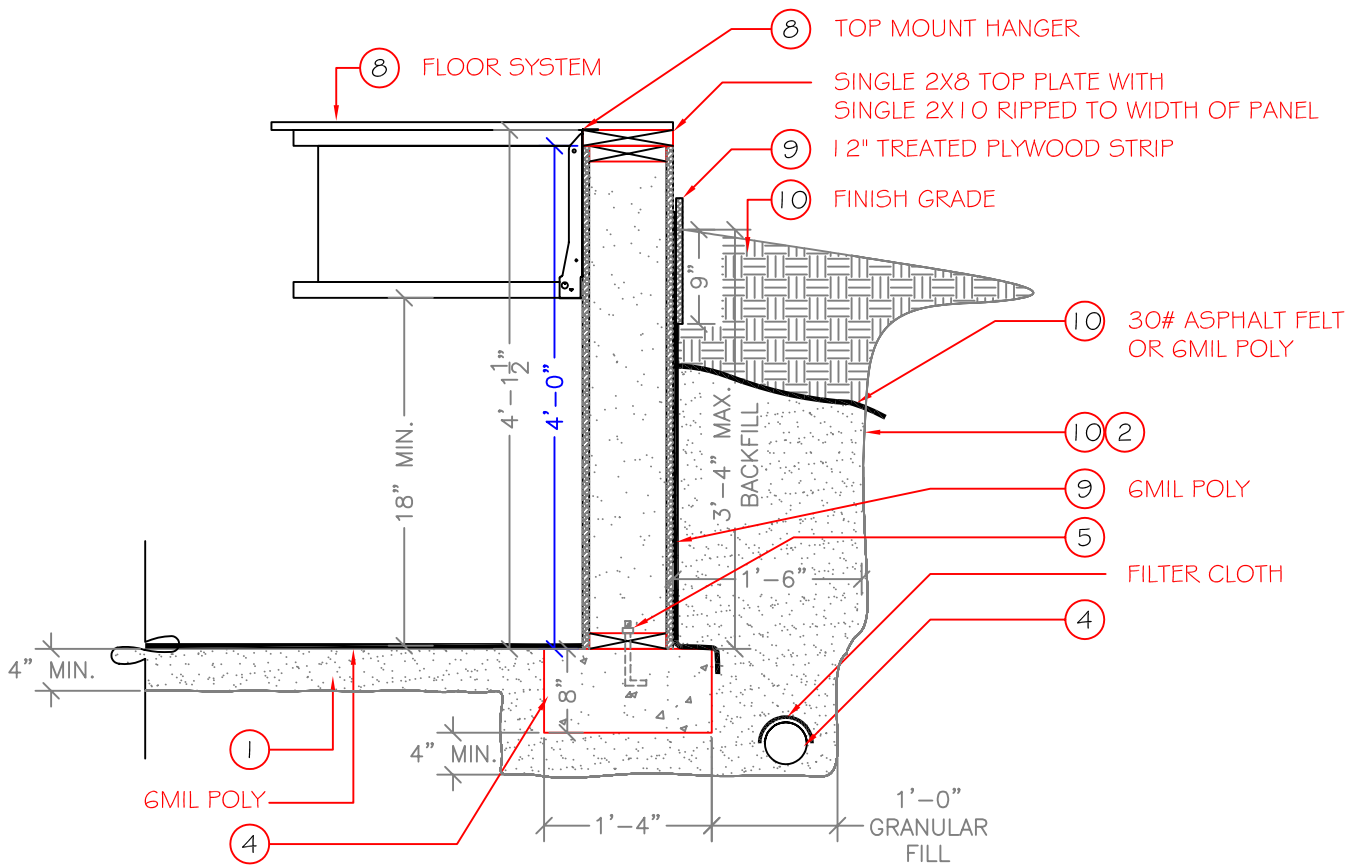
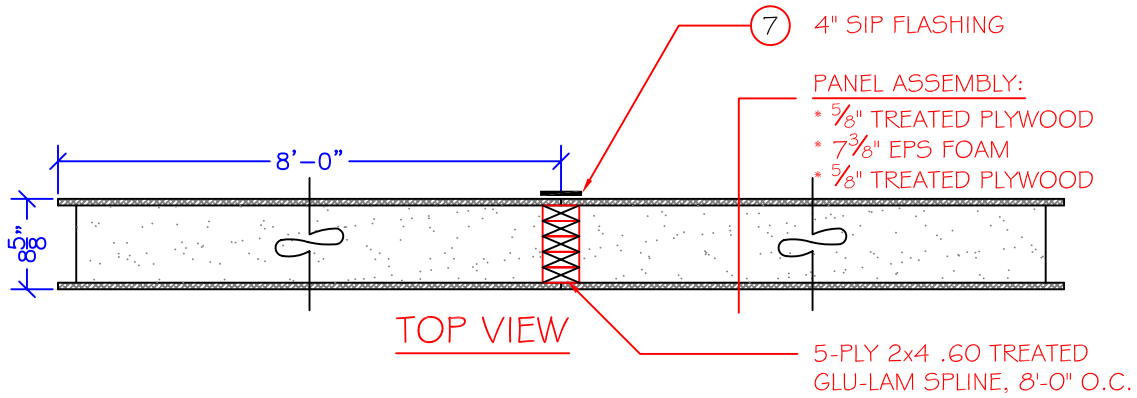

DETAIL TITLE: ALTERNATE TOP PLATES

FOOTING TYPE: CONCRETE FOOTING ALTERNATES

UPDATED: 05/18/05



ENGINEERING & TECHNICAL SERVICES, INC.
 STRUCTURAL ENGINEERING & DESIGN

27121 469th Ave.
 Teo, SD 57064-8100
 (605) 498-1290 OFFICE
 (605) 498-1299 FAX

COPYRIGHT, 2005, ENGINEERING AND TECHNICAL SERVICES, INC.

TABLE 1 – TYPES OF SOILS AND RELATED DESIGN PROPERTIES

Soil Group	Unified Soil Classification Symbol	Soil Description	Allowable Bearing in Pounds Per Square Foot with Medium Compaction or Stiffness ¹	Drainage Characteristics ²	Frost Heave Potential	Volume Change Potential Expansion ³
Group I <i>Excellent</i>	GS	Well-graded gravels, gravel-sand mixtures, little or no fines.	8000	Good	Low	Low
	GP	Poorly graded gravels or gravel-sand mixtures, little or no fines.	8000	Good	Low	Low
	SW	Well-graded sands, gravelly sands, little or no fines.	6000	Good	Low	Low
	SP	Poorly graded sands or gravelly sands, little or no fines.	5000	Good	Low	Low
	GM	Silty gravels, gravel-sand-silt mixtures.	4000	Medium	Medium	Low
	SM	Silty sand, sand-silt mixtures.	4000	Medium	Medium	Low
Group II <i>Fair to Good</i>	GC	Clayey gravels, gravel-sand-clay mixtures.	4000	Medium	Medium	Low
	SC	Clayey sands, sand-clay mixture.	4000	Medium	Medium	Low
	ML	Inorganic silts and very fine sands, rock flour, silty or clayey fine sands or clayey silts with slight plasticity.	2000	Medium	High	Low
	CL	Inorganic clays of low to medium plasticity, gravelly clays, sandy clays, silty clays, lean clays.	2000	Medium	Medium	Medium ⁴
Group III <i>Poor</i>	CH	Inorganic clays of high plasticity, fat clays.	2000	Poor	Medium	High ⁴
	MH	Inorganic silts, micaceous or diatomaceous fine sandy or silty soils, elastic silts.	2000	Poor	High	High
Group IV <i>Unsatisfactory</i>	OL	Organic silts and organic silty clays of low plasticity.	400	Poor	Medium	Medium
	OH	Organic clays of medium to high plasticity, organic silts.	-0-	Unsatisfactory	Medium	High
	Pt	Peat and other highly organic soils.	-0-	Unsatisfactory	Medium	High

1 Allowable bearing value may be increased 25 percent for very compact, coarse grained gravelly or sandy soils or very stiff fine-grained clayey or silty soils. Allowable bearing value shall be decreased 25 percent for loose, coarse-grained gravelly or sandy soils, or soft, fine-grained clayey or silty soils.

2 The percolation rate for good drainage is over 4 inches per hour, medium drainage is 2 to 4 inches per hour, and poor is less than 2 inches per hour.

3 For expansive soils, contact local soils engineer for verification of design assumptions.

4 Dangerous expansion might occur if these soil types are dry but subject to future wetting.